



Ducerf Processed Wood 2nd transformation

Ducerf group - Language 

DUCERF
GROUPE 



Customer relationship

- An individual follow-up of sales in France and internationally.
- Quick answers to your questions and your needs from a dedicated support team.



Tools and technologies

- A flexible production tool to meet specific demands.
- A continuous investment policy to stay ahead in a changing market.

Service

- Very high reactivity thanks to a large stock.
- An expert team in international flow management.
- The provision of sales assistance tools.



Innovative, standard & tailored products

- An R&D division at your service for collaborative development of innovative products.
- **For industry** (door and windows manufacturing): finger jointed or solid scantlings and door frames.
- **For interior design** (interior fittings, stairs, furniture, worktops, ...): a range of solid, finger jointed and three-ply panels.
- **For exterior design** (cladding, decking, public and private spaces, ...): a range of cladding and decking in THT wood or natural wood.



Ducerf Processed Wood

Since 1962, the manufacturing unit of “Les Bois Profilés” is specialised in **second transformation**.

The main products of this Ducerf Group branch are panels and finger jointed scantlings, but it also offers a wide range of high-quality products, processed and treated with advanced technology equipment.

3

manufacturing sites in France: “Les Bois Profilés” (2 units) in Charolles (71), and “Bourgogne Bois Industrie” in Beire-le-Châtel (21)

14 500 m³
of products per year

20 000 m²
of sheds

13 500 m³
of annual kiln drying capacity

Bois Profilés



The mark of responsible forestry

Discover our certified products FSC®

Bourgogne Bois Industrie



Summary

Pages 4.5

PANOLOT

Pages 6.7

3 PLIS

Pages 8.9

PATCHWOOD

Pages 10.15

PROFILEO

Pages 16.23

Cladding

Pages 24.27

Decking

Pages 28.29

Finishes cladding & decking

Pages 30.31

Oak Decking

Pages 32.33

Thermoprocess- Certifications

Pages 34.37

Fitting advices



The Panoplot® is a ready-to-use panel made of solid full stave lamellas glued together on the side and in the width. It is intended for the manufacture of stair steps, tabletops, furniture, decoration, etc. It adapts to any common use of solid wood.

PANO PLOT



Natural Oak (RUSTIC)

Advantages

- Ready to use
- Time saving / productivity gain
- Cost effective
- Drying guarantee
- High stability
- Optimised storage

The product

- Lamellae with 40 mm and up
- Sanded on 2 faces
- Cut to available dimensions
- Individually wrapped with film
- PEFC™ or FSC® certification according to species

Qualities

Cabinet making oak:

tolerance of small sound integrated knots (diam. 5 mm max), panels in matching colour, sound sapwood admitted for back face

«Authentic» oak: sapwood-free quality 1bis/2 without sapwood. Choice 2X backing

Natural oak (Rustic):

filled sound knots, glued (diam. 25 to 30 mm max), panels in matching colour, sound sapwood admitted for back face

Beech: tolerance of traces of red heartwood on back face

Information

- Species: oak, unsteamed and steamed beech
- All woods used are dried to 10% +/- 2%
- Gluing used D3 (for the interior)



PANOLOT®

SPECIES	THICKNESS	SOLD BY m ²				
		13 mm	19 mm	26 mm	31 mm	40 mm
	WIDTH	950 mm* / 1220 mm on demand				
Cabinet making oak (1) (2)	900 to 1600 mm*	•	•	•	•	•
	1800 to 2000 mm	•	•	•	•	•
	2200 / 2400 mm	•	•	•	•	•
Authentic Oak (1)	1200 / 1400 / 1600 / 1800 mm		•	•		•
	2000 / 2200 / 2400 mm		•	•		•
Natural oak (RUSTIC)*** (1)	1400 / 1600 mm		•	•		•
	1800 mm		•	•		•
	2000 / 2200 / 2400 mm		•	•		•

SPECIES	THICKNESS	SOLD BY m ²		
		19 mm	26 mm	40 mm
	WIDTH	950 mm* / 1220 mm on demand		
Steamed beech A/B (1) or (2)	900 to 1600 mm**	•	•	•
	1800 to 2000 mm	•	•	•
	2200 / 2400 mm	•	•	•
Unsteamed beech A/B (1) or (2)	900 to 1600 mm**	•	•	•
	1800 to 2000 mm	•	•	•
	2200 / 2400 mm	•	•	•

*For 19 and 26 mm: lengths from 1000 mm only

(1)



PANOLOT orders must be made up of a variety of lengths (with the exception of 19 mm, which can be ordered in fixed lengths). Should lengths ordered be out of stock, similar lengths will be offered to the client.

(2)



The mark of responsible forestry

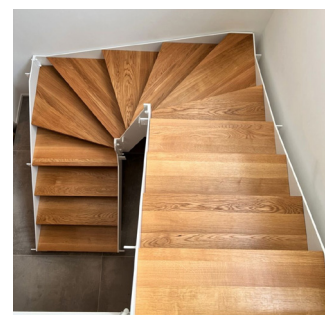



THREE-PLY PANELS

The 3 ply panel is of high quality, both from a technical and aesthetic aspect. It consists of continuous lamellas for the exterior sides and counter-crossed lamellas finger-jointed for the internal ply.

For manufacture of tabletops, furniture, decoration. It is designed to satisfy any common application of solid wood.

 **3PLIS**



Advantages

- Very high stability
- Ready to use
- Time saving / Productivity gain
- Cost effective
- Drying guarantee
- Optimised storage

The product

- **2-ply exterior:**
full stave lamellas 80 or 140 mm in width, thickness 5 mm
- **1-ply interior:**
counter-crossed lamellas finger-jointed, thickness 10 to 16 mm
- Sanded on 2 faces with 80 GR
- Individually wrapped with film
- FSC® panels certified

Qualities

- A/B quality

Information

- **Species:** oak, unsteamed beech, steamed beech, ash, maple, birch, alder, cherry, walnut
- All woods used are dried to 10% +/- 2%
- Gluing used D3 (for interior)



3 ply panels — 20 mm thickness - 1250 mm width

SPECIES / LENGTHS	SOLD PER m ²						
	750/ 800/1000 mm	1250 mm	1650 mm	2050 mm	2300 mm	2500 mm	2700/3000 mm
Cabinet making oak	•	•	•	•	•	•	•
Natural Oak (RUSTIC)	•	•	•	•	•	•	•
Unsteamed or steamed beech	•	•	•	•	•	•	•
Maple	•	•	•	•	•	•	•
Birch - Alder	•	•	•	•	•	•	•
Ash	•	•	•	•	•	•	•
Walnut	•	•	•	•	•	•	

3 ply panels — 26 mm thickness - 1250 mm width

ESSENCE / LONGUEUR	SOLD BY m ²			
	1250 / 1650 mm	2050 mm	2500 mm	3000 mm
Oak	•	•	•	•
Unsteamed or steamed beech	•	•	•	
Maple	•	•	•	
Birch - Alder	•	•	•	
Ash	•	•	•	

All panels are unit wrapped.



Table "55" Tolix®



Natural Oak (RUSTIC)



La marque de la gestion forestière responsable

FSC® on demand



Patchwood® panels are made of finger-jointed lamellas in their length and laminated along the width. It is usually used for worktops, tabletops, furniture, interior decoration, and available in several sizes to meet all your interior design needs and requirements.



Advantages

- Large sizes available: standard 4 m, up to 6 m
- Ready to use
- Time saving / Productivity gain
- Cost effective
- Drying guarantee
- High stability
- Optimised storage

The product

- Lamellae width: 20 mm and 40 mm (+/- 2 mm)
- Cut to available dimensions
- Sanded on 2 faces
- Individually wrapped with film

Quality

- A/B quality

Information

- Species: oak, beech, ash ...
- All woods used are dried to 10% +/- 2%
- Gluing used D3 (for the interior)



PATCHWOOD®

20 mm Lamellae (+/- 2 mm) – Panel length 4000 mm – 650 or 950 mm width (1250 mm on demand)

SPECIES	SOLD BY m ²				
	19 mm	26 mm	31 mm	40 mm	50 mm
Oak	•	•	•	•	•
Unsteamed beech	•	•	•	•	
Steamed beech	•	•	•	•	•
Ash	•	•	•	•	

40 mm Lamellae – Panel length 4000 mm – 650 or 950 mm width

SPECIES	SOLD BY m ²			
	19 mm	26 mm	31 mm	40 mm
Oak A/B	•	•	•	•
Unsteamed beech	•	•	•	•
Steamed beech	•	•	•	•



PEFC
on demand



FSC® on
demand

La marque de la
gestion forestière
responsable



The Profileo® range, finger jointed or solid scantlings, is designed for doors and windows manufacturing. The following combinations are available allowing for cost effectiveness according to their use: visible joinery, 100% solid wood joinery, wood-aluminium windows...



FSC® on demand

La marque de la gestion forestière responsable



Advantages

- High stability
- Ready to use product
- Cost effective
- A number of quality combinations available: DKD, KKK...
- Certifications FSC® or PEFC™ according to species

The product

- Solid or finger jointed layers
- Widths: 75 – 86 – 95 – 105 – 115 – 125 – 145 mm
- Thicknesses: 63, 72 or 84 mm depending on combinations
- Delivered S2S
- Planing, profiling, cutting to length on request

Quality

- A wide choice of species, qualities and constructions according to end use (interior, exterior, to be painted or varnished)

Information

- Glued according to standard DIN D4
- Certification of gluing CTB-Lca
- Moisture content 11% guaranteed (+ or - 2%)



Exterior joinery applications

JOINERY TO BE PAINTED

Species	Description	Widths	Thicknesses	Lenghts
French oak /Chestnut	KKK :2 external layers finger jointed QF1a1b+ 1 or 2 middle layer(s) finger jointed QF1Axx S2S	75-86 95-105 115-125 145 mm	63 mm (KKK) (21+21+21)	4500 or 6000 mm (maxi)
			72 mm (KKK) (22+28+22) or (24+24+24)	
			84 mm (KKKK) (21+21+21+21)	
Brown oak	KKK : 3 layers finger jointed, same specification same as QF1a1b – S2S	75-86 95-115 125 mm	63 mm (KKK) (21+21+21)	4500 or 6000 mm (maxi)
			72 mm (KKK) (22+28+22) or (24+24+24)	
			84 mm (KKKK) (21+21+21+21)	



PEFC on demand

JOINERY TO BE VARNISHED

Species	Description	Widths	Thicknesses	Lenghts
French oak	DKD : 3 layers, external solid layers QF1a1b, middle layer finger jointed QF1Axx	75-86 95-105 115-125 145 mm	63 mm (DKD) (21+21+21)	Lenghts from 100 to 100 Distribution by order : 600 to 1400 mm - 40% 1500 to 1900 mm - 30% 2000 to 2400 mm - 25% 2500 to 3000 mm - 5%
			72 mm (DKD) (22+28+22)	
			84 mm (DKKD) (21+21+21+21)	
French oak /Chestnut	KKK :2 external layers finger jointed QF1a1b + 1 or 2 middle layer(s) finger jointed QF1Axx – S2S	75-86 95-105 115-125 145 mm	63 mm (KKK) (21+21+21)	4500 or 6000 mm (maxi)
			72 mm (KKK) (22+28+22) or (24+24+24)	
			84 mm (KKKK) (21+21+21+21)	
White oak	3 layers – external layers solid Prime grade – middle layer finger jointed or full length	75-86 95-105 115-125 145 mm	63 mm (DKD) (21+21+21)	Lenghts Distribution by order : 2130 mm and more - 80% 920 to 1830 mm - 20%
			72 mm (DKD) (22+28+22) or (24+24+24)	
			84 mm (DKKD) (21+21+21+21)	



PEFC on demand

Due to constant variations in the cost of raw materials, scantlings offers are made on the basis of quotations.

Interior joinery applications

JOINERY TO BE PAINTED

Species	Description	Widths	Thicknesses	Lengths
Beech	3 (or 4) layers - Finger jointed FF1AR (KKK)	73-93-103-123 163 mm	63 mm	2200, 4500 ou 6000 mm (maxi)
French oak	KKK : 3 or 4 layers QF1Axx S2S	75-86-95-105-115 125-145 mm	63 mm (KKK) (21+21+21)	4500 ou 6000 mm (maxi)
			72 mm (KKK) (22+28+22) ou (24+24+24)	
			84 mm (KKKK) (21+21+21+21)	



PEFC on demand

Other sections, qualities and compositions on request.

JOINERY TO BE VARNISHED

Species	Description	Widths	Thicknesses	Lengths
French oak /Chestnut	KKK : 2 external layers finger jointed QF1a1b + 1 or 2 middle layer(s) finger jointed QF1A xx S2S	75-86-95-105-115 125-145 mm	63 mm (KKK) (21+21+21)	4500 or 6000 mm (maxi)
			72 mm (KKK) (22+28+22) ou (24+24+24)	
			84 mm (KKKK) (21+21+21+21)	



PEFC on demand

NEW

PANELS FOR CUTTING – FOR YOUR CUSTOM GLULAM SCANTLINGS

Species	Description	Widths	Thicknesses	Lengths
Beech	Patchwood type panel Boards of 42 mm (+/- 2 mm) - Quality FFAR Raw glued Not cut to length	504 mm	63 mm	4400 mm
French Oak	Patchwood type panel- Boards of 22 mm (+/- 2 mm) - Quality QF1a1xx - Raw glued Not cut to length	704 mm	66 & 72 mm	4600 mm



PEFC on demand

DOOR FRAMES IN FRENCH OAK

- Quality to BE VERNISHED
- Interior and exterior joinery applications
- French oak
- On request: widths, thicknesses and other dimensions
- Lengths: 700 to 900 mm, 2100 mm
- Packaging: delivered on pallets of around 150 pieces, including stiles and rails

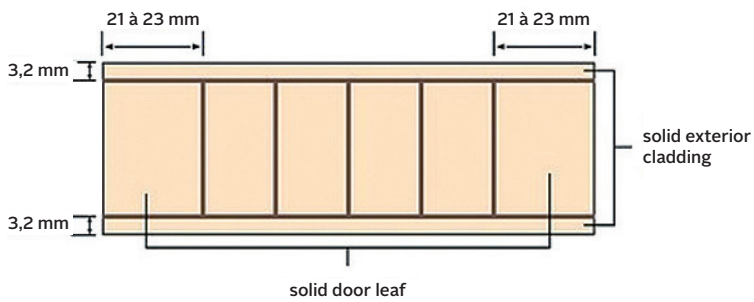

PEFC on demand

PACKAGING

Beech	per pallet (approx. 2 m ³)
French Oak (KKK) / Brown oak / Chestnut (KKK)	approximately 2 m ³ single section per pallet
French Oak (DKD)	single section per pallet with different lengths
White oak	per pallet (approx. 1,5 m ³)



Chestnut/ KKK



French Oak / DKD



White Oak / DKD



Beech / KKK



SOLID OAK/BEECH STRIPS FOR INTERIOR FITTINGS

Solid oak or steamed beech slats for the creation of screen walls and slatted walls. These slats are manufactured in our workshops using wood from French forests. 1st choice strips, uniform appearance.



PEFC on request for the product families concerned



Natural Oak
QF1A1B/QF1AXX

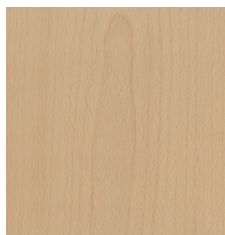

Steamed beech
Quality FFA

Characteristics

- Finger-jointed strips in natural oak or steamed beech, long lengths possible, up to 6m
- 4-sides planes, 1 split edge for 40mm boards
- Finger-jointed D4 (elements 250 to 950 mm in all lengths)
- Modern, natural style
- Easy to install
- Blends in with all decorative styles
- Ideal for adding character to a room, defining boundaries without partitioning or adding a natural decorative touch.
- All finishes possible

Advantages

- Local wood species
- 100% natural material
- Design and aesthetics

Information

- Species: Oak 1st choice 1A/1B without sapwood. Steamed beech 1st CHOICE FFA
 - Widths: 40, 70 and 90 mm
 - Thickness: 21 and 28 mm
 - Lengths: 2.50 and 3m
 - Packaging: pallets from 1.5m³
- Certification: 70% PEFC



Natural Oak QF1A1B

SLATTED WALL

Strips for interior fittings

SPECIES	THICKNESS	WIDTH	STANDARD LENGTHS	SOLD BY ML
				finger jointed strips
Natural Oak QF1A1B	21 mm	90 mm	2500 / 3000 mm	•
		70 mm	2500 / 3000 mm	•
		40mm	2500 / 3000 mm	•
	28 mm	90 mm	2500 / 3000 mm	•
		70 mm	2500 / 3000 mm	•
		40mm	2500 / 3000 mm	•
Natural Oak QF1AXX	21 mm	90 mm	2500 / 3000 mm	•
		70 mm	2500 / 3000 mm	•
		40 mm	2500 / 3000 mm	•
	28 mm	90 mm	2500 / 3000 mm	•
		70 mm	2500 / 3000 mm	•
		40 mm	2500 / 3000 mm	•
Steamed beech FFA	21 mm	90 mm	2500 / 3000 mm	•
		70 mm	2500 / 3000 mm	•
		40 mm	2500 / 3000 mm	•

For other lengths, please contact us.

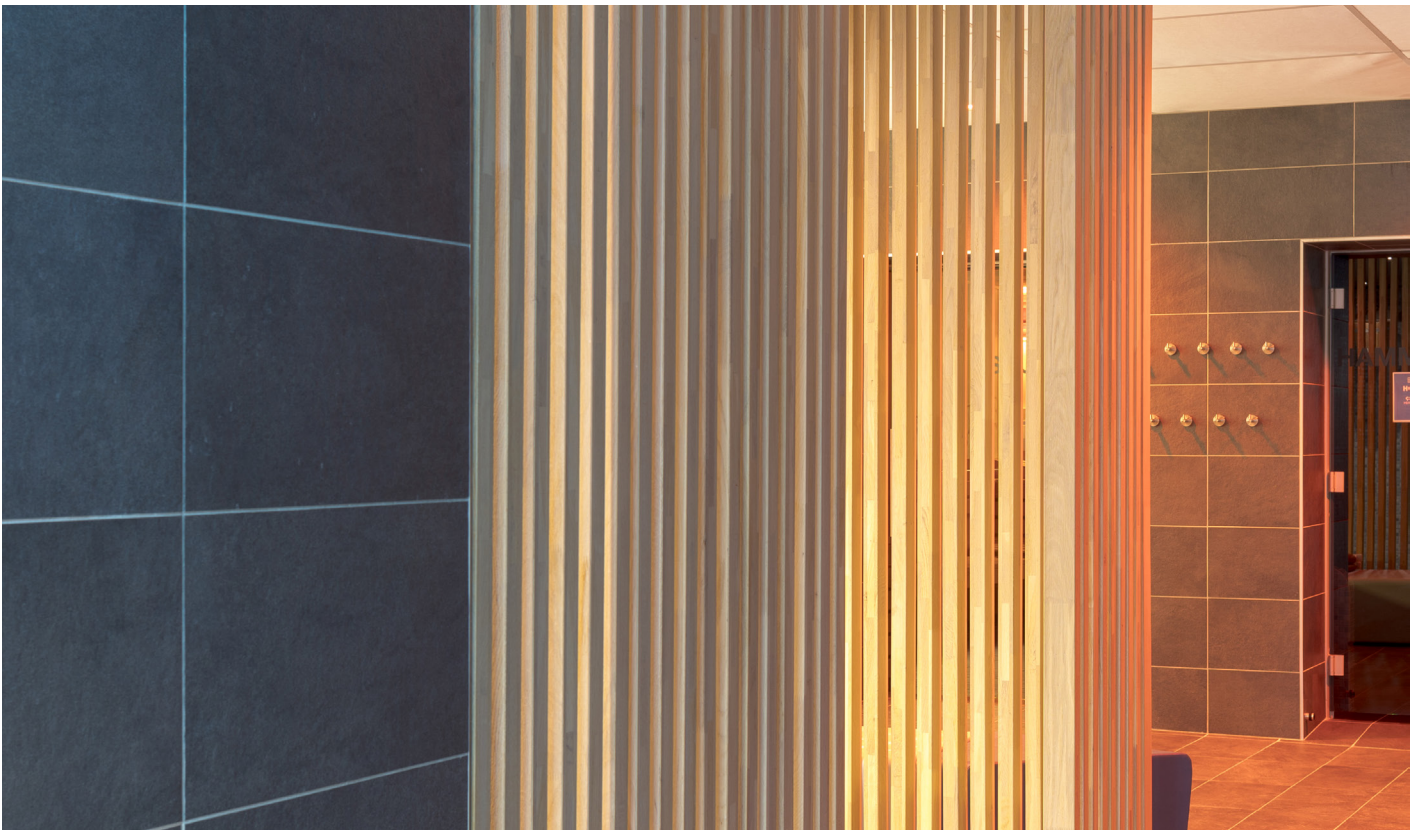

Aquatic centre la Palestra - photos Erwann Pencreach



CLADDING

For tongue and groove or slotted cladding, consistent and durable species should be chosen, which are suited to the location and installation method.

Côtéparc® has selected local species to create a range of hardy, durable, ecological and aesthetically pleasing cladding products made of hard and soft woods, or thermo-treated (THT) wood.

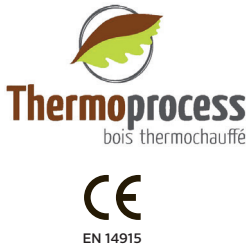

PEFC on request and for the product families concerned

THT Advantages

- Increased durability
- Resistant to insects and fungal attack
- Greater dimensional stability
- Local wood species
- 100% natural materials and treatment
- Develops a homogenous grey colouring
- Can be finished

The product

- Natural or thermo-treated wood cladding
- 7 product profiles from standard to highly bespoke, tongue and groove or clerestory type
- Full length or finger jointed boards
- Jointing compliant with DTU
- MUF ply gluing available (exterior)
- Made to order profiles available (subject to project assessment)

Species

- Hardwoods: Ash THT, Poplar THT, Natural Oak
- Other species on request



Natural Oak QF2X

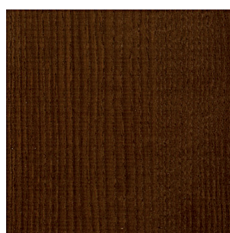

THT Ash A/B

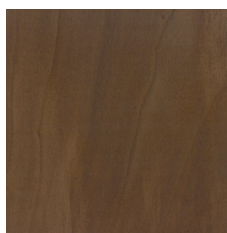

THT Poplar A/B



House- Bard 105 in poplar THT

Bard 104 in poplarTHT



Aquatic center la Palestra



CLADDING

Some unique inspirations for THT wood cladding...
with a variety of profiles and species to suit your creativity.

Flat profile
BARD 100

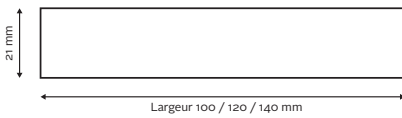

Parallelogram profile
BARD 101

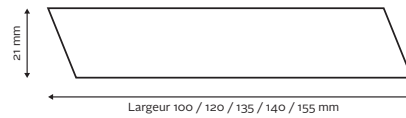

Clerestory cladding
BARD 102

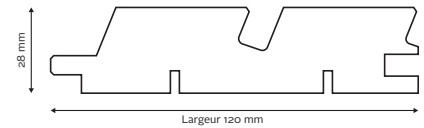

Rounded profile
BARD 103

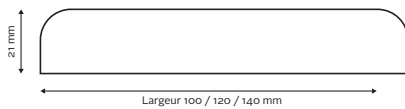

Vertical clerestory cladding
profile **BARD 104**

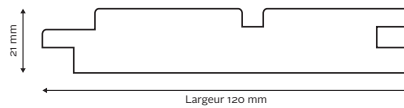

Vertical profile
BARD 104 BIS

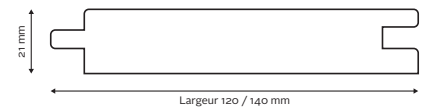

The thicknesses and widths available for each profile can be found on page 20.



CLADDING

RÉFÉRENCE	SPECIES	THICKNESS	TOTAL WIDTH	VISIBLE WIDTH	SOLD BY m ² ACTUAL USABLE SURFACE AREA	
					Full lenght boards	Finger jointed boards
ELEGIE	THT Ash A/B	21 mm	120 mm	110 mm	•	
			140 mm	130 mm	•	
	THT Poplar A/B *	21 mm (solid) 19 mm (finger jointed)	120 mm	110 mm	•	•
			140 mm	130 mm	•	•
	Natural Oak QF2 X	21 mm (solid) 19 mm (finger jointed)	120 mm	110 mm	•	•
			140 mm	130 mm	•	•
BARD 100 BARD 101 BARD 103	THT Ash A/B	21 mm	120 mm	120 mm	•	
			140 mm	140 mm	•	
	THT Poplar A/B*	21 mm (solid) 19 mm (finger jointed)	65 mm (BARD 100 uniquement)	65 mm	•	•
			120 mm	120 mm	•	•
		140 mm	140 mm	•	•	
BARD 102	THT Poplar A/B*	28 mm	120 mm	110 mm	•	on demand
BARD 104 BARD 104 bis	THT Ash A/B	21 mm	120 mm	110 mm	•	
			140 mm	130 mm	•	
BARD 105	THT Poplar A/B	40 ou 60 mm	60 ou 40 mm	60 ou 40 mm	•	•
			40 mm	40 mm	40 mm	•
BARD 106 CARBON (minimum order 50m ²)	THT Poplar	21 mm	140 mm	130 mm	•	
BARD 107 TEXTURE	Natural Oak QF2	19 mm (finger jointed)	110 mm	100 mm		•
			120 mm	110 mm	•	
	Natural Oak QF2X	21 mm (solid)	140 mm	130 mm	•	
			140 mm	130 mm		•
	THT Poplar	19 mm (finger jointed)	140 mm	130 mm		•
			21 mm (solid)	120 mm	110 mm	•
	THT Ash	19 mm (finger jointed)	140 mm	130 mm		•
			21 mm (solid)	120 mm	110 mm	•
			140 mm	130 mm	•	
BARD TINY	THT Poplar	14 mm (solid)	140 mm	124 mm	•	

Full lenghts boards without tongue & groove (mm)

Ash : 1200 / 1600 / 2000 / 2400 ; Poplar : 1200 / 1800 / 2400 / 3000

Oak : 1200 / 1600 / 2000 / 2400

Full lenghts boards with tongue & groove (mm) : All species : lenghts 80% 2000 mm & more

Finger jointed boards : 3000 to 6000 mm, lenghts of the elements from 250 to 900 mm - Supplied with custom-made fittings.



Poplar THT cladding - Gauthier transports



THT Ash - Architect Emeline Poulain



THT poplar Bard Tiny- Tybivouac

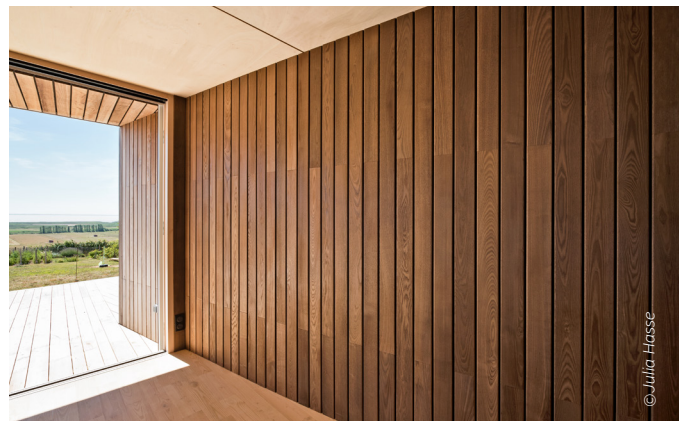



BARD 106 FINITION CARBON

The Bard 106 carbon finish is a thermo-treated poplar cladding with a modern look, rough sawn and with an Intense Black finishing.

A new jointed profile has been specially developed to give a uniform appearance to the cladding and allow invisible fixing.

Advantages

- **New: Jointed profile BARD 106**
- **Visible face rough sawn**
- **New finish colour**
- **Ecological saturator for a ready-to-use product**
- **Thermo-treated wood cladding**
- **Light and design**
- **Increased durability**
- **Greater dimensional stability**
- **Local species**
- **Material and treatment 100% natural**
- **Long life finishing**



The product

- **Available in full lengths boards (Variety of lengths : 800, 1200, 1600, 2000, 2400, 3000 mm)**
- **A/B quality**
- **Visible sections : 21 x 110mm et 21 x 130mm**
- **Thickness : 21 mm**
- **Processing : Visible face rough sawn, 2 beveled edges, planed back faces, 2 tongue and groove edges.**



BARD 107 TEXTURE

Bard 107 Texture is a wall cladding solution with a structured surface and a sensory design pattern.

Modern and trendy, this range of profiled boards will give a new dimension to your interior design projects.

Advantages

- 100% natural wood interior design product
- Unique structured surface finish
- Inspired by nature
- Easy to install and maintain
- Fits in with all decorative styles
- Ideal for adding character to a room, for delimiting without partitioning or for adding a natural decorative touch
- Local wood species
- Design and aesthetics

The product

- Available as continuous boards (a range of lengths: 800, 1200, 1600, 2000, 2400mm) or finger-jointed boards (lengths on request)
- Processing: structured face, 2 chamfered edges, planed counter faces with stress relief grooves, 2 profiled edges, end tongue groove.



Bard 107 Texture Natural Oak QF2



Natural Oak
QF2



Natural Oak
QF2X



THT Poplar

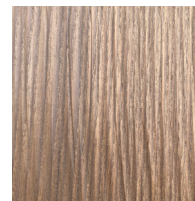

THT Ash



Bard 107 Texture natural oak QF2X



CôtéParc® decking offer several technical, aesthetic and environmental benefits thanks to the use of local woods and Thermoprocess® treatment.

By using the right species in the right place, the wood continues to provide durability in the face of time and weather for many years.



PEFC on request and for the product families concerned

Advantages

- Ready to use
- Local species
- Natural hardness of hard and soft woods
- Develops a homogenous grey colouring
- Resistant to insects and fungal attack
- Exceptional durability
- Greater dimensional stability
- 100% natural materials and treatment
- Can be finished

The product

- Natural ou thermo-treated wood decking
- Local species
- Choice of smooth or grooved boards
- Full stave or finger jointed boards
- Staves cut along the length
- Standard or invisible fixings



Natural Oak QF2 without sapwood

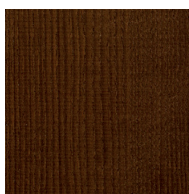

THT Ash



Natural Acacia

Information

- PU finger jointed (exterior)
- Choice A/B: A being the reference side

LES PROFILS DE LAMES

Smooth/grooved – Standard fixing / Invisible fixing B-Fix® (on request)

Full stave boards

Ash : 1200 / 1600 / 2000 / 2400

Acacia depending on the raw material available : 1000 / 1500 / 2000 / 2500 ; soit : 1200 / 1600 / 2000 / 2400

Oak : 1200 / 1600 / 2000 / 2400

Finger jointed boards : 3000 à 6000 mm, lengths of éléments from 250 to 900 mm

Packaging: Panaché de longueurs (20% inférieures à 2000 mm).

SPECIES	THICKNESSES	TOTAL WIDTH	SOLD BY m ²	
			Full stave boards	Finger jointed boards**
Natural Oak QF2 without sapwood	21 mm	120 mm	•	•
		140 mm	•	•
THT Ash A/B	21 mm	120 mm	•	
		140 mm	•	
Natural acacia A/B	21 mm	100 mm	•	•
		120 mm	•	•

* Smooth face visible – only available for standard fixings - ** Minimum order volume 1000 ml



Smooth face, standard fixing



Grooved face, standard fixing

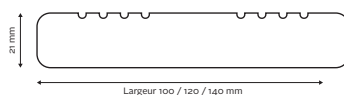

Curved decking smooth face
Standard or invisible fixing



Smooth face, invisible B-Fix® fixing

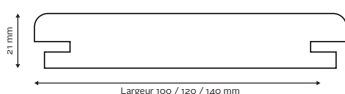

Grooved face, invisible B-Fix® fixing

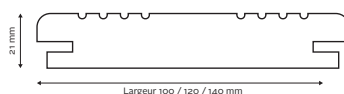



DECKING

BATTENS

SPECIES	LENGTHS	WIDTHS	THICKNESSES	SOLD BY Lm (linear metre)
Natural Oak without sapwood	2000 / 2500 / 3000 mm	70 mm	45 mm	
Autoclave Soft wood (PINE CL4)	4500 / 5000 mm	70 mm	45 mm	



Other sections available, please ask us



Parc Icade - THT Ash decking



"Hôtel de la Poste" Charolles - THT Ash decking



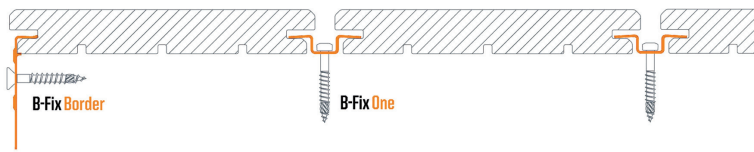

Thermo treated ash decking

B-FIX® INVISIBLE FASTENING SYSTEM



Invisible fixing for decking of 21 mm thick. An impeccable finish, quick and easy to install, always removable, even center planks.

PACKAGE CONTENT		QUANTITY REQUIRED	SOLD BY BOX
Bronze border finish 	50 pieces per box	20 Lm of border per box	
Black fixing 	100 B-Fix® One (stainless steel 301) / 100 B-Screws / 1 Torx Bit / For 5 to 6 m ² / 1 instructions notice	4.8 m ² /box width 120 mm and 5.6 m ² /box width 140 mm	

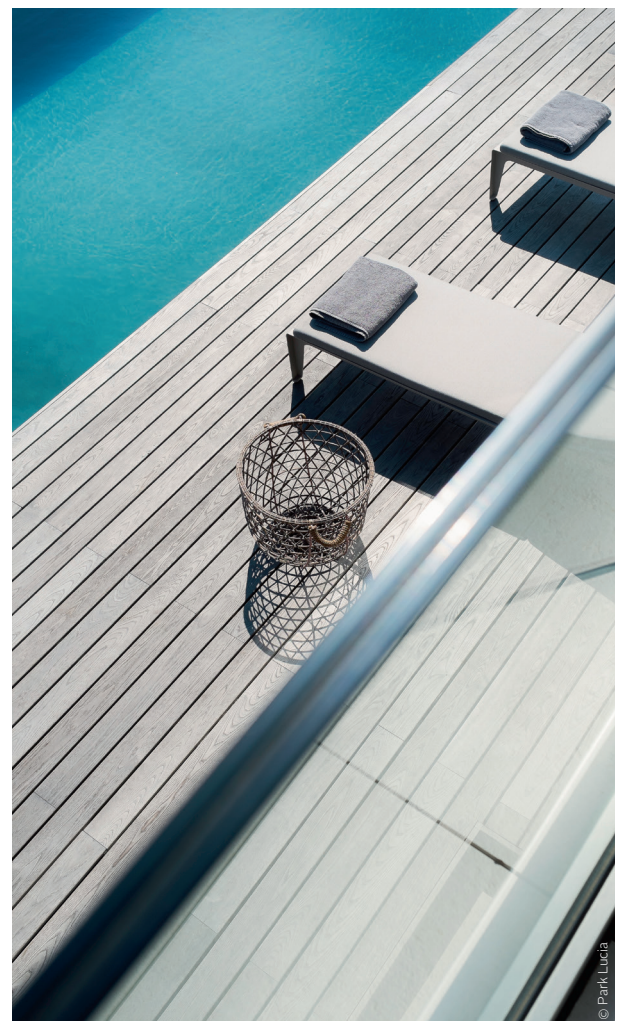
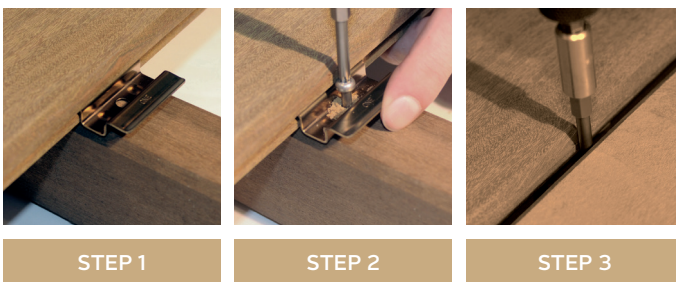

Casa Park Lucia - Ash decking THT, B-Fix® invisible fixing



FINISHES DECKING-CLADDING

To meet the needs of your project, our products can be given a range of technical and aesthetic finishes.

To maintain, protect or brighten up your outdoor THT wood, we offer a range of easy-to-use, durable and easy-to-maintain saturators.

Apply by hand or via our service provider for a ready-to-use product.

Here are a few examples of colours, other shades are available,
Please contact us for the full colour chart. (Sikkens brand)



(Photos and colours non-contractual)



Thermo treated ash decking *FinishLook IPE Saturabois® flnvisible fixing B-Fix®*

Fire-retardant finish:

Hardwood cladding > 18 mm thick is classified M3. In the case of regulatory constraints concerning establishments open to the public, intumescent finishes can be applied for interior use. These improve the reaction to fire of the cladding by slowing the progress of flames. This finish gives a Euroclass classification of M1 or B-s1,dO.

Factory application for a ready-to-use product

Water-based saturator (colourless, THT wood stain, grey)

CLADDING

Application on the face of the profile and edges of the profile

			Supplement to be added to the indicative sales price excluding VAT/m ²		
Ref. / Species	Thickn.	Total width	25 - 50 m ²	50 - 150 m ²	more than 150 m ²
with production start-up package					

ÉLÉGIE / BARD 100 / BARD 101 BARD 102 / BARD 103 / BARD 104

Ref. / Species	Thickn.	Total width	25 - 50 m ²	50 - 150 m ²	more than 150 m ²
Oak THT QF2X	21 mm or 28 mm depending on the profile	65 - 100 120 - 135 - 140 155 mm depending on the species & the profile	•	•	•
Ash THT A/B					
Poplar THT A/B					
Natural Oak					
Maritime Pine THT OA					

BARD 105

			Supplement to be added to the indicative sales price excluding VAT/ml		
Ref. / Species	Thickn.	Total width	200 - 400 ml	400 - 1250 ml	more than 1250 ml
with production start-up package					

Application on the face and edges of the profile

Ref. / Species	Thickn.	Total width	200 - 400 ml	400 - 1250 ml	more than 1250 ml
Poplar THT A/B	60 mm	40 mm	•	•	•
Maritime pine THT OA	40 mm	40 mm	•	•	•

Application on all sides of the profile

Ref. / Species	Thickn.	Total width	200 - 400 ml	400 - 1250 ml	more than 1250 ml
Poplar THT A/B	60 mm	40 mm	•	•	•
Maritime pine THT OA	40 mm	40 mm	•	•	•

CORNER PROFILES

Application on all sides of the profile

			Supplement to be added to the indicative sales price excluding VAT/ml		
Ref. / Species	Thickn.	Total width	200 - 400 ml	400 - 1250 ml	more than 1250 ml
Oak THT	66 mm	66 mm	•	•	•
Ash THT					
Poplar THT					
Natural Oak					

DECKING

Application on the face of the profile and edges of the profile

			Supplement to be added to the indicative sales price excluding VAT/m ²		
Ref. / Species	Thickn.	Total width	25 - 50 m ²	50 - 150 m ²	+ de 150 m ²
with production start-up package					

Ref. / Species	Thickn.	Total width	25 - 50 m ²	50 - 150 m ²	+ de 150 m ²
Natural Oak QF2 no sapwood	21 mm or 27 mm depending on the profile	100-120-135 140-145-155 mm depending on the species & the profile	•	•	•
Ash THT A/B					
Maritime Pine THT OA					
Natural acacia A/B					
Natural Douglas Fir without sapwood					



OAK DECKING

For outdoor use, oak is king. This reliable material enhances any landscaping while guaranteeing excellent quality and durability. The Ducerf Group's oak decks are especially popular for building footpaths, pontoons, decking or public walkways. For increased flexibility, these are available in the rough, planed or planed/grooved.

The product

- **PREMIUM Oak decking**
- **Limited sound knots to half the width of the board**
- **No knots on edges**
- **Except sapwood**
- **Core heart traces tolerance (on the back side)**
- **Stamp custom-sized 1 to 2 cm**
- **Wood dried to 25/30%**

Advantages

- **Ready to use**
- **Local species**
- **Natural hardness of hard and soft woods**
- **Can be finished**
- **Lengths: 2500 to 4000 mm**
- **Oak decking: planed, planed/grooved**
- **Can be cut to size from fresh sawn timber**



PREMIUM OAK DECKING



Lengths : 2500 to 4000 mm

SECTION (mm)	PLANED		PLANED + SQUARE CUT	
	145	45	145	45

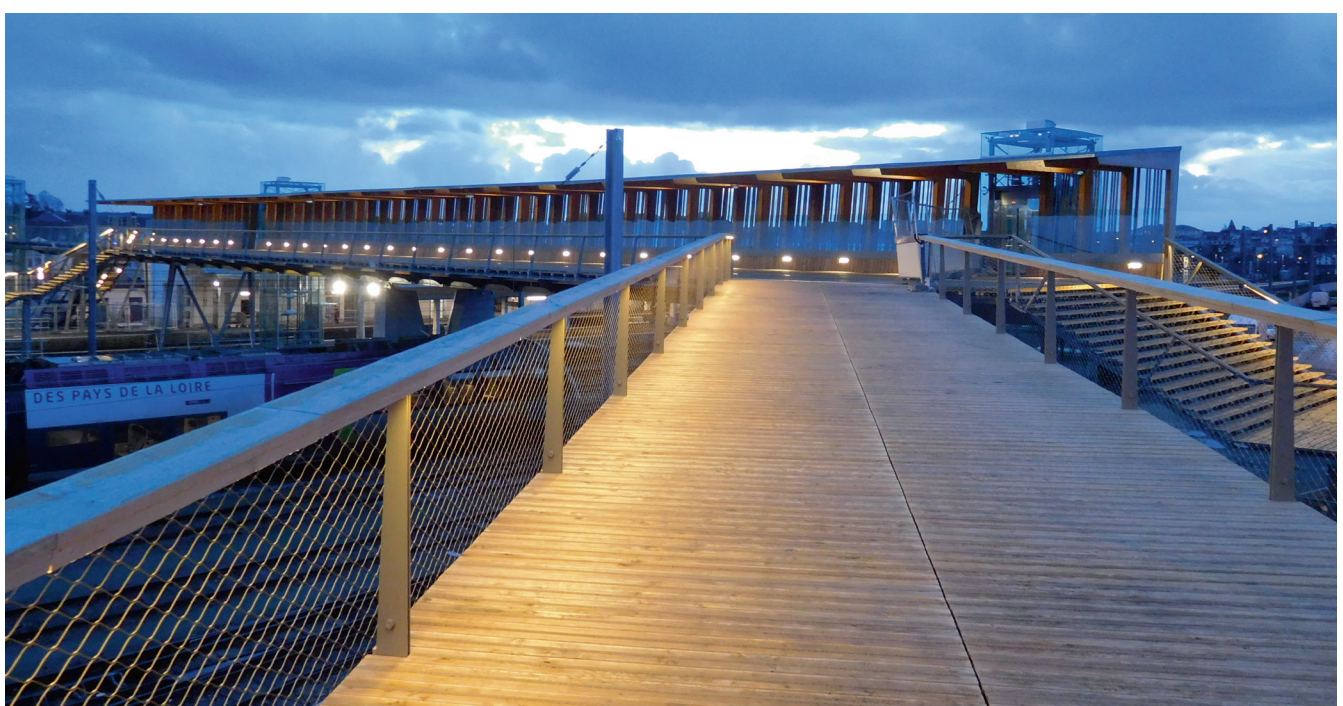
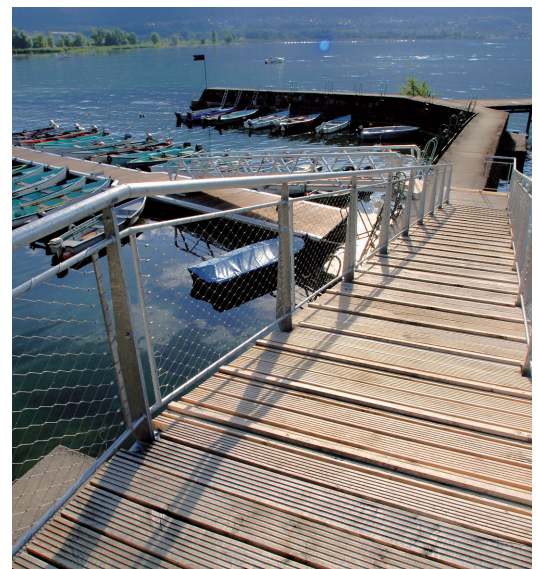
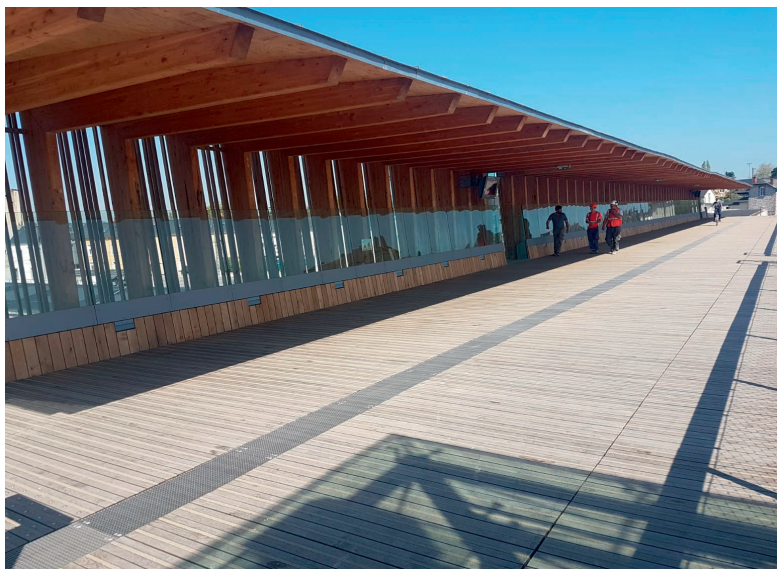



THE THERMOPROCESS® TECHNOLOGY

ThermoProcess is a process for treating wood by heating it to a high temperature. It changes the characteristics of the wood, making it more stable and durable. The process also improves waterproofing and changes the aesthetic appearance of the wood.

The ThermoProcess is carried out in **3 precisely controlled stages** using high-tech equipment:

1. Heating up :

The oven rapidly heats up to 100°C with steam. The wood is then fully dried in a more gradual temperature rise to 130°C. The atmosphere of superheated steam with a low oxygen content prevents splitting and affects the reactions induced in the wood. At the end of this phase, the moisture content of the wood tends towards 0%. Good management of this stage is essential to wood processing and its duration depends on a combination of parameters such as: the initial moisture content of the wood, the species and the size of the sawn timber treated.

2. High-temperature treatment :

It is from a temperature of around 150°C that the modifications and transformations inside the wood take place. The temperature inside the kiln is then raised to between 160°C and 230°C, depending on the desired treatment. The chosen temperature is maintained for 2 hours, depending on the desired characteristics. During this phase, precise control of the installation with, for example, a steam supply prevents the wood from carbonising.

3. Cooling and re-humidification:

During this final stage, the drop in temperature inside the kiln is again accompanied by the spraying of cold water mist. A slight recovery of moisture in the wood occurs from 90 to 80°C. A further short heating phase is then carried out to ensure that the wood is properly re-humidified. Depending on the treatment conditions and the desired characteristics, this phase lasts between 5 and 15 hours.

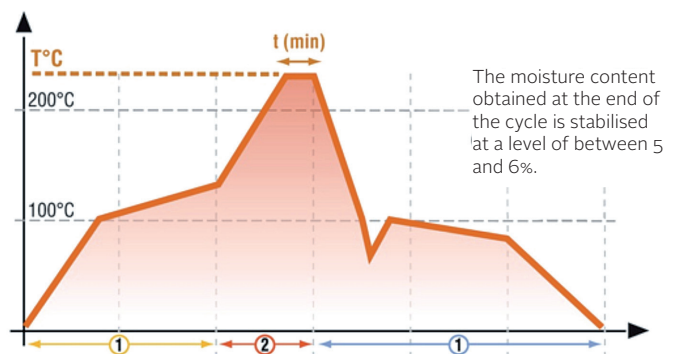

4. The benefits :

THT treatment gives wood remarkable properties:

- Better resistance to fungal attack and wood-eating insects
- Greater dimensional stability
- Increased durability
- Equilibrium humidity reduced by around 50%.
- New natural, homogenous colours reminiscent of tropical woods
- 100% natural and easily recyclable
- Reduced extractables (tannins, resins)
- Can be glued and finished with finishing products
- Increased wood rigidity
- Reduced breaking stress
- Density reduced by around 10%

5. Species characteristics :

	Oak (without sapwood)	Thermo-treated Oak	Thermo-treated Ash	Thermo-treated Poplar	Acacia
Density (kg/m ³)	700-800	600-700	550-650	350-400	720-800
Young's Modulus (MPa)	12,500	14,250	19,000	10,000	13,600
Monnin Hardness	Medium-hard to hard (3<d<5N/mm)	Medium-hard (3<d<5N/mm)	Medium-hard (3<d<6N/mm)	Very soft (0.5<d<3N/mm)	Hard (5<d<9.5N/mm)
Stability	Medium	Good	Good	Good	Weak
Fungal durability and use class :					
Durability (Class 3a)	>100 years	>100 years	>100 years	>100 years	>100 years
Durability (Class 3b)	50-100 years	50-100 years	50-100 years	50-100 years	50-100 years
DURABILITY (CLASS 4)	<10-50 years	<10-50 years	<10-50 years	<10-50 years	<10-50 years
Applications	Decking, Cladding	Cladding	Decking, Cladding	Cladding	Decking, cladding
Fastening Method	Pre-drilling recommended	Pre-drilling recommended	Pre-drilling recommended	Nail gun	Pre-drilling recommended

CERTIFICATIONS

With a strong commitment to sustainable forest management at national level and after being the first sawmill in France to obtain PEFC certification for its wood control chain, the DUCERF Group companies have maintained their efforts to retain their certifications and guarantee products derived from good forest management with very high quality standards. We also have CTB-LAMELLES COLLES ABOUTES gluing certification. Our various production units, Les Bois Profilés and Bourgogne Bois Industrie, each have the following certifications:

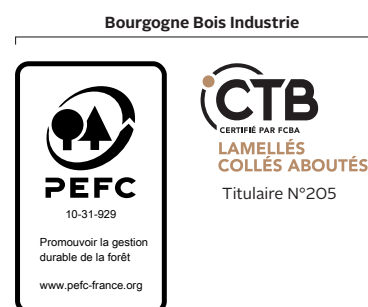
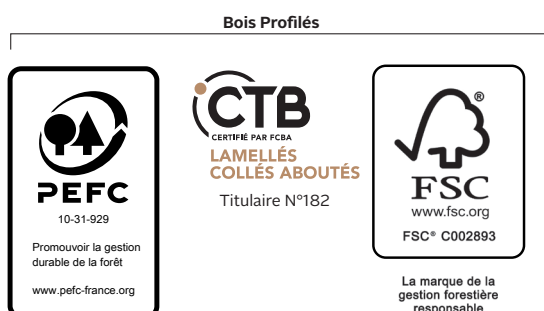



INSTRUCTIONS FOR USE PANOPLLOT, PATCHWOOD & 3 PLIS

To read first

The panels are only intended for interior use where contact with splash water or condensation is very short term.

Wood is subject to dimensional movements (shrinkage/swelling) due to changes in humidity.

In order to prevent this, the following recommendations must be observed.

Storage

Store the filmed panels flat on top of each other in a dry, closed room. Insulate them from the ground by laying them on battens spaced 1 m apart and orientated in the direction of the width.

Only remove the plastic film when applying the finish.

Cut outs

Leave a minimum of 20 cm between two cuts and 10 cm from the longitudinal edge in the panel.

Finishing

Apply the appropriate finish for the purpose before installation and assembly of the panels with a minimum of two coats.

Apply an identical finish (volume of product and number of coats) to each side and edge to balance the moisture content of the panel.

For an oiled or varnished finish, apply the same number of coats on each side and edge at the same time to balance out the worktop.

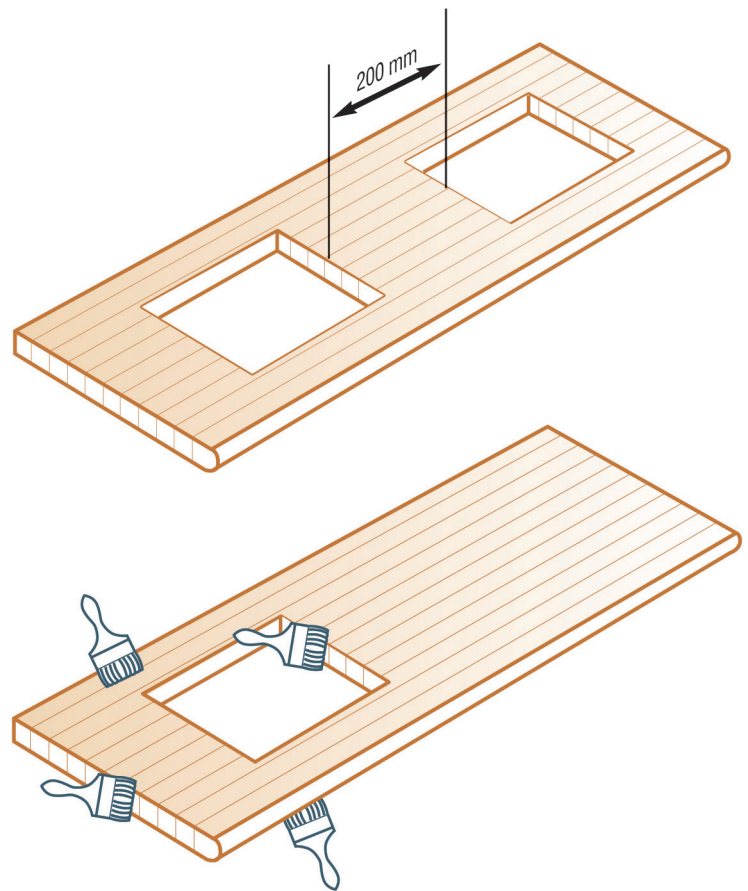

BEWARE !

Appliances that generate heat (pans, etc.) must not be placed directly on the panels.
Use a heat-resistant insert (trivet, etc.).

The adhesives used for the manufacture of the panels are classified as DIN D3, panels for interior use only.

GENERAL INSTALLATION SPECIFICATIONS

Dimensional variations can occur mainly in the width and thickness of the worktop. It is therefore necessary to leave an expansion gap at the various fixing points. Furthermore, the panel must not rest directly on a solid support, it is imperative to leave a gap of 3 to 5 mm between the panel and the walls.

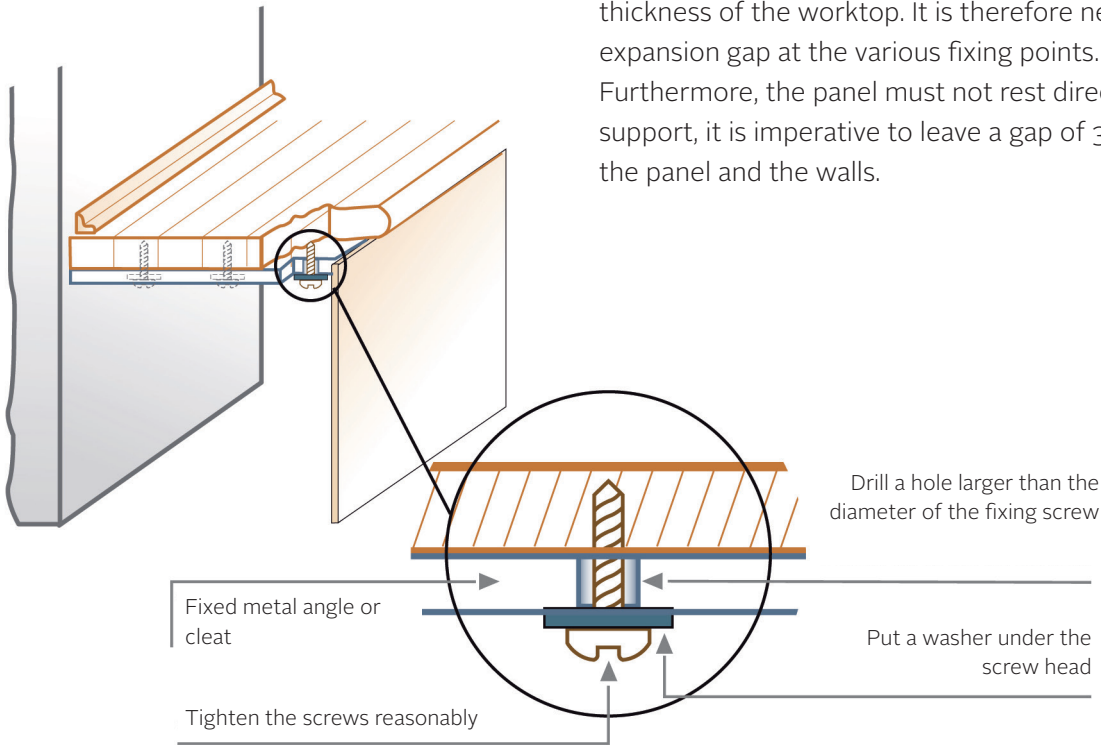

SPECIFIC INSTALLATION TIPS PANOPLLOT & PATCHWOOD

If the panel is to be screwed in place, a hole larger than the diameter of the screw should be drilled in the support part so that the panel can absorb the dimensional movements.

For use as a work surface, leave a gap of 3 to 5 mm between the panel and the wall.

Apply a silicone-type sealant to fill the gap..

Screw fixing

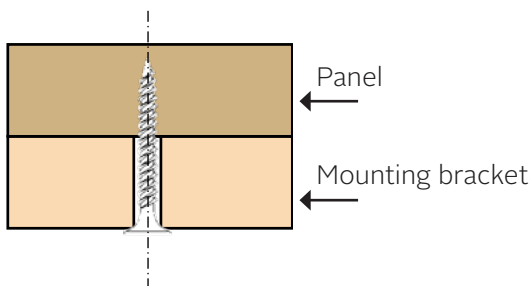

SPECIFIC INSTALLATION TIPS 3 PLIS

In cupboard doors, if the width of use is greater than 35 cm, it is recommended that a frame be fixed to the back or around the 3-ply panel. Below is a suggested application for wall cladding.

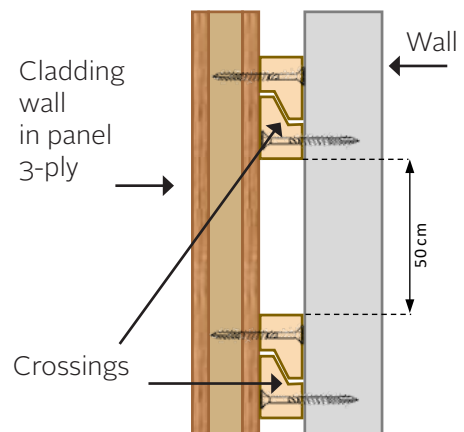

USE

Depending on the use and the finish applied, provide adequate maintenance.



CLADDING

For standard profiles only, other cases: consult us.

The installation advice given above is indicative and non-contractual: it is a matter of usual and general rules to be respected, but it is not exhaustive; these rules must be completed and adapted on a case-by-case basis, according to the precise environment in which the products will be used. Installation by the customer assumes that he/she has the minimum technical skills to do so; if this is not the case, and in the event of any doubt or difficulty whatsoever, it is the customer's responsibility to consult a professional or your sales advisor before any intervention.

The different roles of wood cladding:

- Aesthetic role: exterior finish of a building,
- A mechanical role: to guarantee resistance to impact and friction,
- A functional role: guaranteeing watertightness thanks to the rain screen, reinforcing the thermal resistance of the wall thanks to the thermal insulation provided by the wood and the air gap.

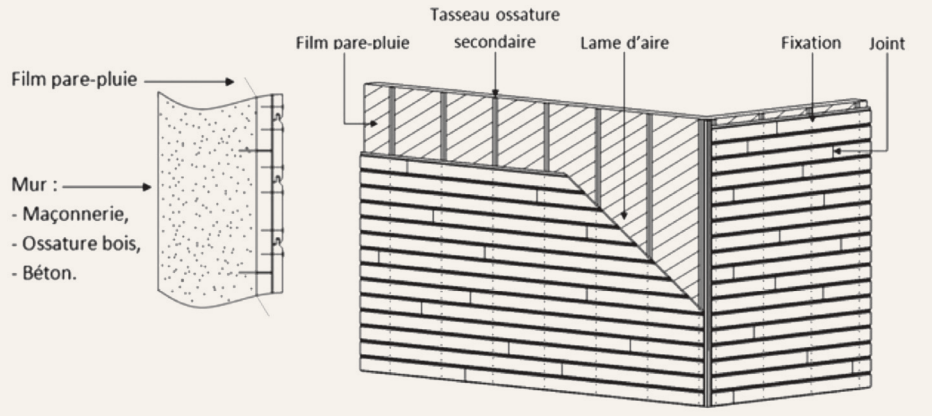

Rainscreen film :

- Permeance: 0.5 g/m².h.mm.Hg,
- Fixing by the battens,
- Horizontal overlap 50 mm,
- Vertical overlap 100 mm.

Orientation of the boards :

Tongue always upwards if laid horizontally or tongue facing the prevailing wind if laid vertically.

Joints:

DUCERF products are assembled by tongue and groove at the end. The joints can then be found between two battens.

Precautions for low finishes:

- Distance between cladding and floor \geq 200 mm,
- Distance between cladding and masonry connection \geq 30 mm,
- Suggestion: install a rodent
- Suggestion: install an anti-rodent grid.

Arrangement of the battens according to the direction of installation of the cladding boards :

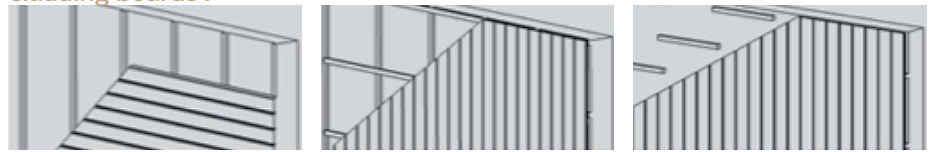

Horizontal installation : vertical battens

Vertical installation : double battening

Vertical installation: staggered battens

Planks: secondary framing :

Fixings :

- Stainless steel wood screws,
 - Stainless steel nails,
 - Doweling (concrete walls).
- Treatment: minimum class 3,
Section: see table on the right.

Fixing the cladding :

- Screw with fillet under head (min. 22 mm),
- \varnothing 3.5 or 4 mm max, length depending on the thickness of the cleats,
- Penetration into the cleats :

centre distance of cleats (cm)	minimum cross-section of cleats (mm)	maximum distance between 2 fixings of the same cleat (cm)
30 (on a masonry wall)	15 x 35	30
40	22 x 40	40
60	27 x 40	60

- 22 mm min,
- Pre-drill the end of the blade to the diameter of the screw,
- Stainless steel fasteners,
- Self-drilling countersunk head screw,
- Number and location: see table:

Board width	Visible width	number and location of fastener(s)
100 mm	90 mm	1 visible fixing per support at approx. 15 mm from the bottom of the groove.
120 mm	110 mm	
140 mm	130 mm	2 visible fixings per support at 1/3 and 2/3 of the board width.

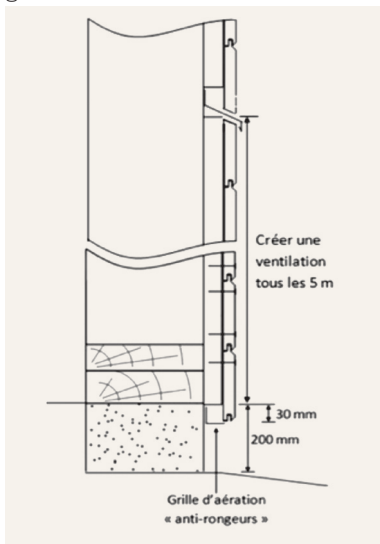

Technical solution for outward facing corners, panel cladding :

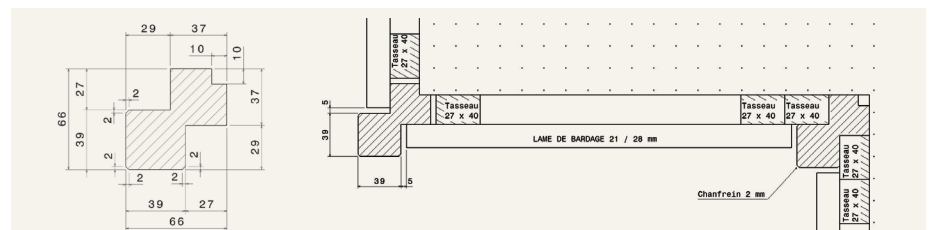

DECKING

For standard profiles only, other cases: consult us.

The installation advice given above is indicative and non-contractual: it is a matter of usual and general rules to be respected, but it is not exhaustive; these rules must be completed and adapted on a case-by-case basis, according to the precise environment in which the products will be used. Installation by the customer assumes that he/she has the minimum technical skills to do so; if this is not the case, and in the event of any doubt or difficulty whatsoever, it is the customer's responsibility to consult a professional or your sales advisor before any intervention.

Design advice :

Joisting: characteristics :
Representation of a joist on planks :

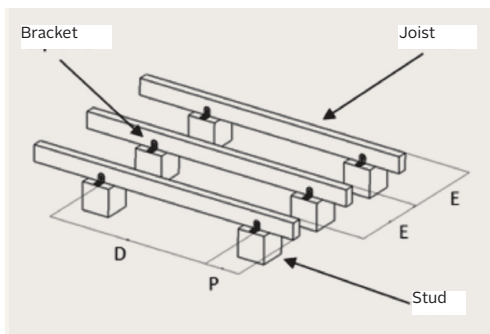

P: max. overhang = $0.15 \times D$
D: distance between studs
E: joist centre distance

The table below shows the recommended joist spacing (E) and stud spacing (D) depending on the joist cross-section:

Decking board	Section (mm)	Centre distance (mm)	Distance between studs (mm)
Oak / Ash THT / Acacia	65 x 40 mm Natural Oak 75 x 40 mm Oak THT	400	500
Oak / Ash THT / Acacia	63 x 43 mm Pine CL4 75 x 50 mm Pine CL4	400	600
Douglas naturel / Douglas traité CL4 / Chêne abouté / Acacia abouté	63 x 43 mm Pin CL4 75 x 50 mm Pin CL4	500	600

Values for wood of strength class C18 / D18.



Pre-drilling recommendation:

- Always for the blade,
- Carry out a countersink to insert the screw head,
- Pre-drilled diameter of 4 mm.

Recommended screws for decking :

- Screws with undercutting,
- min. diameter 5 mm, min. length 50 mm
- Stainless steel screws required (A2 or A4)

Technical sections for implementation

Number of screws

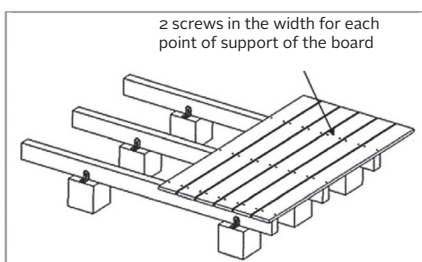

Side overhang :

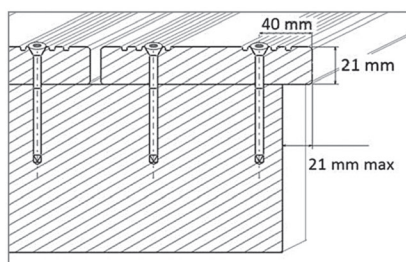

Longitudinal overhang :

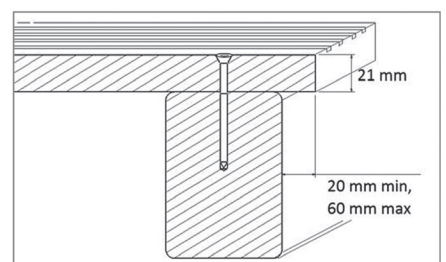

Fixing the boards :

Cross section

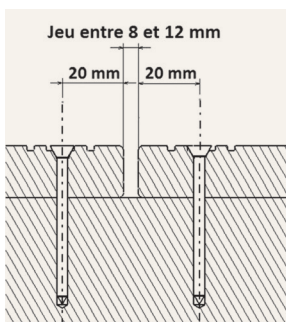

Boards gap :
between 8 and 12 mm

End joint: Longitudinal section

Recommendation: to improve the service life of the decking, prefer the solution ②

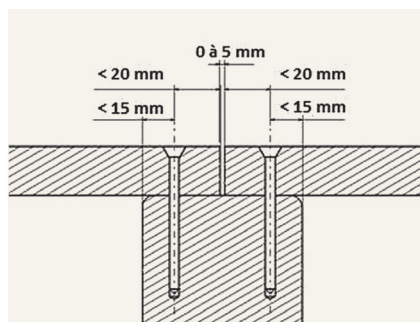

① Board end joint
on a single support

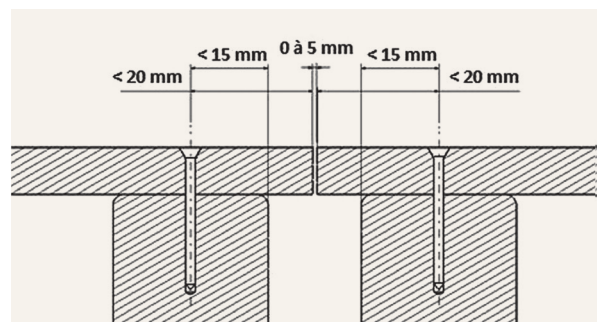

② Board end joint
on double support

CONVERSION TABLE

METRIC CONVERSIONS						
1 centimetre	=	10 millimetres	=	1 cm	=	10 mm
1 decimetre	=	10 centimetres	=	1 dm	=	10 cm
1 metre	=	100 centimetres	=	1 m	=	100 cm
1 kilometre	=	1000 metres	=	1 km	=	1000 m
IMPERIAL CONVERSIONS						
1 foot	=	12 inches	=	1 ft	=	12 in
1 yard	=	3 feet	=	1 yd	=	3 ft
1 chain	=	22 yards	=	1 ch	=	22 yd
1 furlong	=	220 yards (or 10 chains)	=	1 fur	=	220 yd (or 10 ch)
1 mile	=	1760 yards (or 8 furlongs)	=	1 mi	=	1760 yd (or 8 fur)
METRIC -> IMPERIAL CONVERSIONS						
1 millimetre	=	0.03937 inches	=	1 mm	=	0.03937 in
1 centimetre	=	0.39370 inches	=	1 cm	=	0.39370 in
1 metre	=	39.37008 inches	=	1 m	=	39.37008 in
1 metre	=	3.28084 feet	=	1 m	=	3.28084 ft
1 metre	=	1.09361 yards	=	1 m	=	1.09361 yd
1 kilometre	=	1093.6133 yards	=	1 km	=	1093.6133 yd
1 kilometre	=	0.62137 miles	=	1 km	=	0.62137 mi
IMPERIAL -> METRIC CONVERSIONS						
1 inch	=	2.54 centimetres	=	1 in	=	2.54 cm
1 foot	=	30.48 centimetres	=	1 ft	=	30.48 cm
1 yard	=	91.44 centimetres	=	1 yd	=	91.44 cm
1 yard	=	0.9144 metres	=	1 yd	=	0.9144 m
1 mile	=	1609.344 metres	=	1 mi	=	1609.344 m
1 mile	=	1.609344 kilometres	=	1 mi	=	1.609344 km

1 "Les Bois Profilés" - UNIT 1
F-71120 CHAROLLES

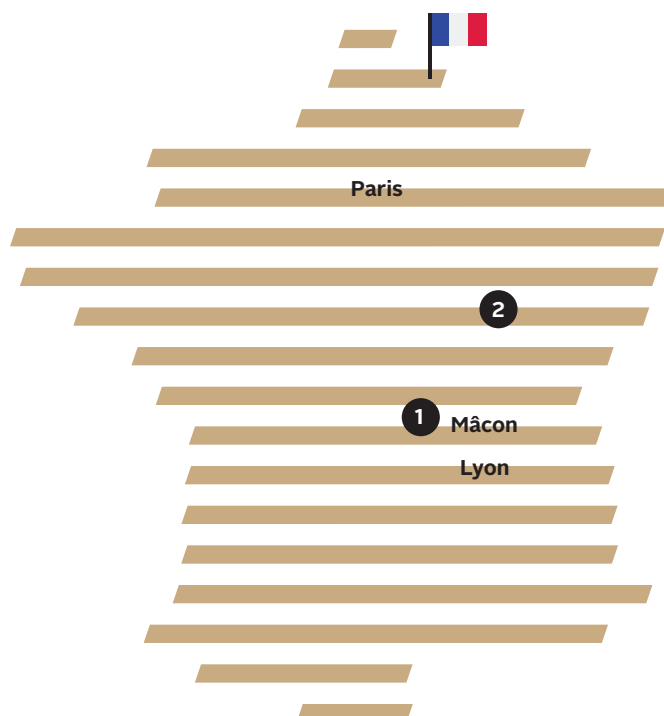

2 "Bourgogne Bois Industrie" - UNIT 2
F-21310 BEIRE-LE-CHÂTEL





In 1885, Jean Ducerf built his first sawmill in Burgundy, at the very heart of one of Europe's largest forest. Generation after generation, the family-owned group grew, spread, established new sites in France, implemented innovative processes and exported to many countries, while evolving with the market. At Ducerf, wood is considered holistically, together with all its applications. The group carries out the first and second transformation of various hardwood species, and mostly oak timber. Concerned about the environment, the family-owned business has adopted an ecologically responsible approach each day. A perfect way to lead by example and contribute to sustainable development. Today, Ducerf Group has become the leader in the timber industry, with very clear motivations: quality, innovation and passion.

Follow us on
our social networks
in a click!



19 avenue Joanny Furtin
F-71120 Charolles
Commercial Team Export
Phone + 33 3 85 88 28 33
Fax + 33 3 85 88 28 23

www.ducerf.com

**LES BOIS
PROFILES**
Ducerf Groupe